



# Influencer Marketing and Behavioral Outcomes: How Types of Influencers Affect Consumer Mimicry?

Kazi Turin Rahman   <sup>1</sup>

*Coventry University, U.K. <sup>1</sup>*

## ABSTRACT

**Objective** - This paper conceptualizes a novel theoretical model of consumer mimicry of various types of influencers and associated behavioral outcomes.

**Design** – This model was conceptualized after a thorough literature review and gap analysis. Moreover, prominent and underrepresented concepts from the literature were integrated to develop the novel model synthesized in this paper.

**Findings** – Many facets of social media influencers have been studied in extant literature. These include source and content characteristics along with marketing strategies and sponsorship disclosures. However, most studies examine influencers from a broad perspective without refinement. Influencers are grouped into four categories based on their following and expertise: mega, macro, micro, and mini-influencers. Such categorizations are rarely reflected in the existing literature. Moreover, consumer mimicry of influencers and the consumer well-being aspects have been largely understudied.

**Policy Implications** -Choosing the right influencer is challenging. Therefore, recognizing which types of influencers evoke consumer mimicry (and which don't) will ease the selection process. This will increase the efficiency of influencer marketing campaigns run by marketers and brands.

**Originality** - This is the first paper to incorporate all four types of influencer categories into a theoretical model. Subsequently, the largely scarce concept in SMI research, consumer well-being, has also been incorporated to ensure followers' welfare.

## ARTICLE INFO

Received: March 10, 2022

Revised: May 8, 2022

Accepted: May 17, 2022

Published: May 27, 2022

### Keywords:

Influencer

Influencer Marketing

Social Media

Consumer Mimicry

Consumer Well-Being

Purchase Intention

Word-Of-Mouth Intention

 © 2022 The Author(s)

 Corresponding author: [kaziturino@gmail.com](mailto:kaziturino@gmail.com)

## Introduction

What do people like Michelle Lewin, Chiara Ferragni, and James Charles have in common? They are all prominent social media influencers (henceforth known as SMIs) specializing in fitness, fashion, and beauty. Such figures are digital content creators. They leverage the power of platforms like Instagram to influence

audiences (Ki & Kim, 2019). The rise of influencers has given birth to a \$13.8 bn industry known as influencer marketing, which shapes consumer behavior through influencers (Schwarz, 2021; Torres et al., 2019). Owing to their authenticity and credibility, companies are increasingly turning towards SMIs to drive their marketing campaigns and boost sales. Hence, influencer marketing has become an essential focal point in theory and practice.

Research on influencer marketing is gaining momentum. So far, studies have focused on how various source and content characteristics influence consumer outcomes (Fink et al. 2020; Schouten et al. 2020; Martínez-López et al. 2020; Trivedi and Sama 2020). The effect of psychological factors and sponsorship disclosures on consumer outcomes has also been investigated (Ki et al. 2020; Ladhari et al. 2020; Van Reijmersdal et al. 2020; De Veirman and Hudders 2020). While the research progress is noteworthy, many outstanding issues still remain. For instance, most studies have not considered how different categories of SMIs (like mega, macro, micro and nano-influencers) affect consumer outcomes (Vrontis et al. 2021). These categories will be discussed in the following sections. Mimicking the actions of SMIs from a consumer perspective is also scarce within extant literature and warrants further investigation (Ki and Kim 2019). Perhaps the most essential issue often skipped in SMI research is consumer well-being, the satisfaction of consumers in various sub-domains (Jin and Ryu 2020).

Therefore, this study aims to address these research above gaps by developing a model that captures the outcomes linked to consumer mimicry of various SMIs. This will be achieved through literature review analysis and theoretical integration. According to Ki and Kim (2019), consumers consider SMIs as role models and tend to mimic their lifestyles and preferences. However, while such actions can evoke purchase and word-of-mouth intentions, they can also lead to a decline in consumer well-being (Jang et al. 2016).

Additionally, SMI's have different influential power based on their following, authenticity, and credibility. Thus, a novel model is needed to conceptualize the interplay of these essential concepts. This paper has followed the theoretical article design set by Yadav (2014). Conceptualizing new relationships by debating existing ones has been the primary focus here.

The rest of the study is organized as follows: An extensive literature review has been undertaken to gauge the current state of SMI research and subsequent research gaps. This includes the elaboration of key concepts, terms, and variables. Moreover, based on the perused literature and gap analysis, a novel model has been presented. Research propositions and implications of the study follow suit.

## Literature Review

### Key concepts

#### *Types of influencers*

Influencers are grouped into various categories based on their follower count, domain expertise, and earning ability (Campbell and Farrell 2020; Association of National Advertisers 2018). Firstly, some mega-influencers have attained equal to or more than 1 million followers on social media. Such SMIs have established expertise and earn around \$50,000 per post from paid brand partnerships. Secondly, there are macro-influencers with followers between 100,000 and 1 million. They participate in selective brand partnerships and have relatively lower earnings at \$5,000 per post. Thirdly, there are micro-influencers with followers between 10,000 and 100,000. Their scope is geographically limited, and they earn mainly through occasional brand partnerships and affiliate-link programs. Finally, some nano-influencers possess 10,000 followers or less. Such newcomers must settle for unpaid alliances in exchange for exposure and networking opportunities (Hudders et al. 2020).

### ***Consumer mimicry and subsequent outcomes***

Mimicry stems from the social learning theory introduced by Bandura (1977). It states that individuals will shape their behavior accordingly to replicate or mimic the behavior of others. Moreover, individuals will consider these ‘others’ as role models. A role model is anyone who can influence the behavior of individuals by engaging with them directly or indirectly (Bandura 1986). Within the context of SMI research, it must be pointed out that consumers regard influencers as role models and aspire to mimic their actions (De Veirman et al. 2017). As a result of consumer mimicry, many social and non-social outcomes emerge like engaging in word-of-mouth (WOM) communication and developing intentions to purchase influencer endorsed products, respectively (Vrontis et al. 2021).

### ***Consumer Well-being***

A consumer's satisfaction in various aspects of life is termed consumer well-being. Dimensions in well-being include self-esteem, self-perception, happiness, etc. (Lee et al. 2021; Burnell et al. 2020). In this digitally interconnected world, a person's well-being primarily depends on how they use online platforms like Instagram and Facebook (Odgers and Jensen 2020). With regards to SMIs, consumer browsing of influencer profiles has mixed consequences. While social comparisons with influencers can dent well-being, following them can boost self-perception (Jang et al. 2016; Kim and Kim 2021). However, consumer well-being is understudied in the context of SMIs, which will be discussed later.

### **Current Scenario of SMI Research**

The credibility and trustworthiness of SMIs contribute to their effectiveness in influencing consumer behavior. Existing studies have adopted various approaches towards unravelling the dynamics behind SMIs. For example, Fink et al. (2020) examined the effect of influencer credibility on purchase intentions. They proved that credible SMIs can persuade consumers to buy endorsed products and the effects last for four years. This is proof that relying on influencer marketing is a long-term investment for brands and companies.

Similarly, comparative studies like that of Jin et al. (2019) and Schouten et al. (2020) have verified that influencer endorsements are more effective than regular celebrity endorsements. Another line of inquiry investigated how followers' intentions for searching for products could increase (Martínez-López et al. 2020). It was found that unity between the influencer and endorsed product was vital in driving interest and content engagement. The importance of influencer-product congruency was also authenticated by Trivedi and Sama (2020). They confirmed that in the context of consumer electronics, influencers with technical expertise were more in demand than their attractive counterparts.

Moving on, Ki et al. (2020) worked on the emotional bonds formed by influencers with their follower base. They concluded that SMIs generate influential power by meeting follower needs like competence, relatedness and ideality. Another study by Ladhari et al. (2020) looked into the emotional attachments formed by beauty influencers with their audiences. The values, attitudes and appearances (known as the dimensions of homophily) projected by such figures are crucial in increasing their popularity and driving recommendations for endorsed products. Regarding sponsorship disclosure, De Veirman and Hudders (2020) stressed that it negatively impacted an influencer's credibility. This is because such disclosures promote ad recognition and induce skepticism among followers. Van Reijmersdal et al. (2020) also made similar conclusions in their study. Issuing a sponsorship disclosure at the beginning of video content was linked to negative attitudes toward the influencer and affiliated brand.

Researchers have also dealt with the aspect of using SMIs as a marketing instrument in previous studies as well. Take the case of Lin et al. (2018); they developed a five-stage strategy for marketers to efficiently promote their products via influencers. These stages include setting promotional objectives (planning),

identifying relevant SMIs (recognition), matching them with the target products (alignment), compensating them appropriately (motivation), and monitoring the influence generated (coordination). This strategy can be used for any product (utilitarian or hedonic) and ensures effective partnerships between SMIs and marketers. Other researchers in this avenue have examined SMI's usage of emojis (pictograms embedded in electronic text messages) as a strategy to drive engagement among followers (Ge and Gretzel 2018). Speaking of driving engagement, hashtags (metadata tags used for cross-referencing social media content) are another aspect utilized by influencers to connect with the audience (Erz et al. 2018).

The discussions above are an overview of what has been found. Altogether, many sub-themes have been discovered and scrutinized within SMI research. Using influencers as marketing mediums and subsequent sponsorship disclosures are some of the examples discussed above. In addition, various content characteristics and influential factors that persuade consumers have also been analyzed. Hence, the next logical question is

## What is Missing?

### *Regarding Influencer Categories*

Vrontis et al. (2021) undertook a systematic review of SMI research to uncover the current state of affairs and existing gaps within the field. Hudders et al. (2020) also conducted a similar review of research focusing on the strategic use of SMIs. The latest systematic literature reviews (and the discussion in the previous section of this study) have revealed that most studies do not explicitly differentiate between the types of influencers investigated. Instead, existing research is focused on a broad construct of SMI without refinement. To contribute to marketing practice, Vrontis et al. (2021) and Hudders et al. (2020) strongly recommend that future studies need to account for all categories of influencers that exist (mega, macro, micro and nano-influencers).

Some studies have done comparative analyses on the persuasion abilities between mega and micro-influencers or mega and nano-influencers (Park et al. 2021; Calverley and Grieve, 2021). *Table 1* presents a list of constructs that rarely appear in the latest SMI research papers found in Scopus and WoS databases. However, none of the papers accounted for all four types of influencers. This further reaffirms that a research gap needs to be addressed, focusing on all types of influencers out there.

*Table 1: Non-exhaustive list of scarcely used constructs in SMI research*

A(Y)	MEI	MAI	MII	NAI	CM	CWB	PI	WION	WIOFF
Fernández and Castillo 2021							x	x	
Park et al. 2021	x		x						
Arenas-Márquez et al. 2021								x	
Calverley and Grieve 2021	x			x					
Jin and Ryu 2020						x	x		
Kay et al. 2020		x	x						
Kim and Kim 2021						x			
Oraedu et al. 2020								x	x
Jin et al. 2019						x			
Ki and Kim 2019					x		x	x	

*A(Y) = author (year) MEI = mega-influencer, MAI = macro-influencer, MII = micro-influencer, NAI = nano-influencer, CM = consumer mimicry, CWB = consumer well-being, PI = purchase intention, WION = word-of-mouth intention online, WIOFF = word-of-mouth intention offline.*

### **About consumer mimicry**

As illustrated in *Table 1* and recent systematic reviews, extant literature only features one study investigating the effects of consumers mimicking influencers. Ki and Kim (2019) used the influence framework to examine how influencers used various strategies to evoke mimicking aspirations among consumers. They confirmed that consumer mimicry of influencers indeed exists. Moreover, they stressed the importance of investigating whether such mimicry exists within different types of influencers as classified above. Hence, there is an opportunity to integrate consumer mimicry into a theoretical model in this study.

Speaking of theories, one of the first systematic reviews on influencer research was done by Sundermann and Raabe (2019) identified theoretical fragmentation across this entire field. Some popular theories to be used in SMI research include the persuasion knowledge model, source credibility theory, and attribution theory (Hwang and Jeong 2016; Djafarova and Rushworth 2017; Singh et al. 2020). Returning to Vrontis et al. (2021), they suggested that further studies needed to integrate theories based on social principles since they are so rare in extant literature. Thus, investigating consumer mimicry is an ideal way forward since it originates from the social learning theory courtesy of Bandura (1977).

### **On consumer well-being**

Consumer well-being is becoming an increasingly prominent topic within marketing and consumption literature. However, SMI research is yet to reflect that as it ignores this important concept entirely. Only three studies in this field deal with consumer well-being, as shown in *Table 2*. For instance, Jin et al. (2019) studied the emergence of envy within followers of influencers on social media. Following a similar path, Jin and Ryu (2020) argued that influencers induced materialistic envy among followers, which only served hedonic motives. Alternatively, Kim and Kim (2021) demonstrated that having a sense of ‘friendship’ with the preferred influencer increased their fans' perceptions of life and well-being. Therefore, it is evident that consumer well-being is vastly understudied in the domain of influencer research and this subsequent gap needs to be addressed.

## **Proposed Model**

Based on the literature review of what has been found and what is missing, the proposed model in *Figure 1* has been synthesized. Said model has three portions; types of influencers (mega, macro, micro, and nano), consumer mimicry, and behavioral outcomes (purchase intentions, WOM intentions, and consumer well-being). The constructs appearing in the model have been explained before putting forward research propositions. Testing these propositions will enable future researchers to validate the proposed model.

### **Consumer mimicry (CM)**

Before moving into the first segment, the second segment, consumer mimicry, needs discussion. There is a desire among people to mimic their role models as per social learning theory. Imitating role models affects consumer purchase intentions and brand preferences (Ruvio et al. 2013). Within the SMI context, De Veirman et al. (2017) states that consumers may perceive influencers as role models and seek to imitate them. The validity of this statement was tested and confirmed by Ki and Kim (2019) in their study of consumer desires to mimic influencers. However, it happens to be the lone study to do so, and they have urged future studies to account for different types of influencers. Thus, consumer mimicry is one of the central tenets in the proposed model shown in *Figure 1*.

### **Mega-influencers (MEI)**

The first category among SMIs is the mega-influencer, those with equal to or more than 1 million followers. Due to their immense following, they enjoy a ‘celebrity’ status on social media. Moreover, they

partner with big brands, and consumers tend to idolize them (Farrell and Campbell 2020). Followers idealizing the imagery created by influencers were also confirmed by Calverley and Grieve (2021). Hence, the first research proposition is as follows:

P<sub>1</sub>: Mega-influencers (MEI) are positively associated with consumer mimicry (CM)

### Macro-influencers (MAI)

Macro-influencers possess a following of between 100,000 and less than 1 million (Hudders et al. 2020). Such influencers have characteristics like inducing positive emotions among consumers. Additionally, they appear more socially desirable and accessible to their followers (Manero and Navarro 2020). Therefore, this study posits the following:

P<sub>2</sub>: Macro-influencers (MAI) are positively associated with consumer mimicry (CM)

### Micro-influencers (MII)

Influencers with followers between 10,000 and less than 100,000 are categorized as micro-influencers (Hudders et al. 2020). While micro-influencers are deemed as more authentic and credible than bigger influencers, they have limited brand partnerships and geographical scope (Kay et al. 2020; Farrell and Campbell 2020). Hence, there are less alluring to consumers owing to their ‘micro-celebrity’ status. In light of these characteristics, the study puts forward another research proposition:

P<sub>3</sub>: Micro-influencers (MII) are negatively associated with consumer mimicry (CM)

### Nano-influencers (NAI)

The ‘newcomers’ in the social media scene, nano-influencers have a follower base of 10,000 or less (Farrell and Campbell 2020). While nano-influencers are hailed for their originality, they do not possess brand partnerships like their bigger counterparts (Oliveira et al. 2019). With a relatively limited fan following, they generally do not spark consumer aspirations to become like them. Henceforth, the following research proposition can be put forward:

P<sub>4</sub>: Nano-influencers (NAI) are negatively associated with consumer mimicry (CM)

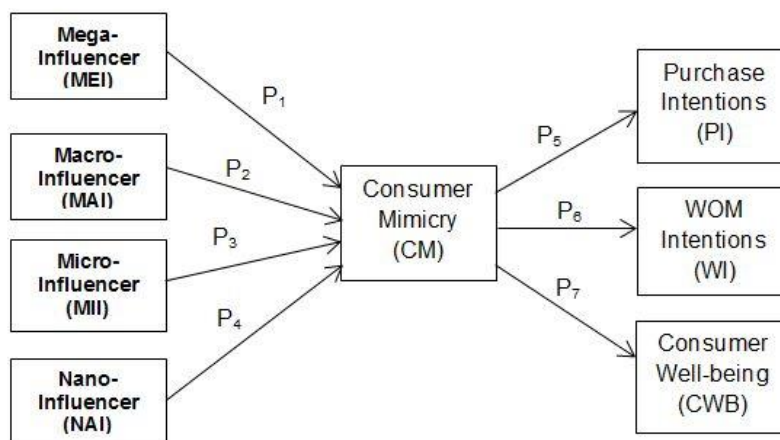

Figure 1: Proposed model on consumer mimicry of SMIs

## Purchase Intentions (PI)

One of the central jobs that marketers expect influencers to do is generate a desire to purchase endorsed products. Moreover, mimicry impacts behavioral outcomes like consumer purchase decisions (Jacob et al. 2011). Mimicking can be a conscious or unconscious process through which an individual tries to replicate a role model's consumption patterns (e.g. product or brand preferences) (Ruvio et al. 2013). In this case, influencers are role models whom followers are trying to imitate. Therefore, when followers see their favorite influencer recommend or try new products, they are inclined to mimic them by purchasing them. Keeping this in mind, the study proposes the following:

P<sub>5</sub>: Consumer mimicry (CM) is positively associated with purchase intentions (PI)

## Word-of-mouth Intentions (WI)

Just like mimicry affects non-social outcomes like purchase intentions, it also involves social outcomes like word-of-mouth (Duffy and Chartrand 2015). Furthermore, on social media, consumers can easily express their opinions regarding their favorite influencers (Kim and Johnson 2016). Just like its online counterpart, offline word-of-mouth is also crucial. However, most studies only focus on the online aspect, depriving the SMI context of a comprehensive understanding of WOM (Oraedu et al. 2020). Thus, it is clear that both forms of WOM are prevalent and another research proposition takes shape:

P<sub>6</sub>: Consumer mimicry (CM) is positively associated with word-of-mouth intentions (WI)

## Consumer Well-being (CWB)

Since imitating influencers involves replicating their consumption patterns, followers may take it too far. Jin and Ryu (2020) proved that compulsive buying and materialistic envy exist among followers. Moreover, Jin et al. (2019) also confirmed the existence of envy among people who followed influencers on social media. Consumer well-being has not been studied enough in SMI research despite being an emerging issue in the marketing literature (Vrontis et al. 2021). Aspects like happiness and self-esteem of followers mimicking influencers need focus. Based on the limited evidence at hand, this study posits the following:

P<sub>7</sub>: Consumer mimicry (CM) is negatively associated with consumer well-being (CWB)

All in all, the propositions presented above will help future researchers to validate the proposed model on consumer mimicry of SMIs. To assist them even further, each construct appearing in the model has also been explained along with the proposed measurement scales below.

Table 2: Proposed scales of constructs appearing in the model

Construct	Definition	Proposed scale	Reference
Mega-influencers (MEI)	The number of followers determines the type of influencer	This can be identified from the number of followers an influencer has	Campbell and Farrell (2020)
Macro-influencers (MAI)		<ul style="list-style-type: none"><li>• An influencer with an excess of 1 million followers is a mega-influencer</li><li>• An influencer with more than 100 thousand followers but less than 1 million is a macro-influencer</li></ul>	
Micro-influencers (MII)		<ul style="list-style-type: none"><li>• An influencer with more than 10 thousand followers but less than 100 thousand is a micro-influencer</li></ul>	

Nano-influencers (NAI)		<ul style="list-style-type: none"> <li>An influencer with 10 thousand or fewer followers is a nano-influencer</li> </ul>	
Consumer mimicry (CM)	Consumers desire to replicate the actions of a role model	<p>4 items to be measured on a 7-point scale.</p> <ul style="list-style-type: none"> <li>I aspire to the lifestyle of this influencer</li> <li>Inspired by this influencer, I want to be as stylish as him/her</li> <li>Inspired by this influencer, I want to be as trendy as him/he</li> <li>Inspired by this influencer, I want to have a lifestyle more like him/her</li> </ul>	Ki and Kim (2019)
Purchase Intentions (PI)	Intentions to acquire products or services	<p>3 items to be measured on a 7-point scale</p> <ul style="list-style-type: none"> <li>In the future, I am likely to try one of the same products that the influencer endorsed or posted about</li> <li>In the future, I am likely to try one of the same services that the influencer endorsed or posted about</li> <li>In the future, I am likely to try one of the same brands that the influencer endorsed or posted about</li> </ul>	Ki and Kim (2019)
Word-of-mouth intentions (WI)	Intentions to informally converse about a service, brand or product	<p>3 items to be measured on a 7-point scale</p> <ul style="list-style-type: none"> <li>I will likely recommend the brands (both online and offline) suggested by the influencers I follow to other people.</li> <li>I am likely to encourage friends and relatives (both online and offline) to buy the brands recommended by the influencers that I follow</li> <li>I am likely to say positive things about the brands (both online and offline) recommended by the influencers that I follow to other people</li> </ul>	Fernández and Castillo (2021)
Consumer well-being (CWB)	Satisfaction with sub-domains of consumer life	<p>All items are to be measured on a 7-point scale</p> <ul style="list-style-type: none"> <li>Happiness (4 items)</li> <li>Self-esteem (1 item)</li> <li>Affect and self-perception (18 items)</li> <li>Fear of missing out (10 items)</li> </ul>	Lee et al. (2021), Burnell et al. (2020)

Table 2 depicts the proposed scales used to measure each construct displayed in the model in Figure 1. The type of influencer in question can be identified using the number of followers they possess. In only a



handful of studies, each type of influencer was used as a construct. Park et al. (2021) investigated the persuasion abilities of mega-influencers in comparison to micro-influencers. Calverley and Grieve (2021) did a comparative analysis between mega-influencers and nano-influencers. Another line of inquiry studied the source characteristics involving macro-influencers and micro-influencers (Kay et al. 2020). As for consumer mimicry, Ki and Kim (2019) used 4 items measured on a 7-point Likert scale to determine the phenomenon's prevalence. Purchase intentions were a consequence of consumer mimicry from the same study and have been adopted for this proposed model as well. WOM intentions were one of the main measurements in the study conducted by Fernández and Castillo (2021) on the behavioral outcomes of influencer brand endorsements. Finally, aspects of consumer well-being like happiness and self-esteem were taken from Lee et al. (2021) and Burnell et al. (2020). Their studies dealt with various psychological and mental consequences of browsing influencer profiles on social media.

## Conclusion

Through literature review analysis and theoretical integration, this study has presented a novel model focusing on the consumer mimicry of SMIs. The current state of SMI research was examined before identifying the gaps in extant literature. Subsequently, the proposed model was developed with relevant constructs, scales, and research propositions. Future researchers are encouraged to validate this model by testing the propositions. This will contribute to theoretical and practical progress in SMI research. Using influencers to promote products is changing the landscape of traditional marketing. This is due to the penetration of modern technological advancements like social media, smartphones, and blockchain (Rahman 2021a; Rahman 2021b; Rahman 2021c). While consumer purchase decisions can be swayed using this method, marketers and influencers must also be wary of adverse consequences. Consumer well-being must be at the forefront of marketing theory and practice to ensure a better tomorrow.

## Implications

The contributions of this paper towards marketing theory and practice need discussion. This is the first paper to incorporate all four types of influencer categories into a theoretical model. Moreover, it expands the dimensions of consumer mimicry of influencers as introduced by Ki and Kim (2019). Investigating consumer mimicry (which stems from social learning theory) also responds to the call for utilizing more social-based approaches in SMI research (Vrontis et al. 2021). Social outcomes like WOM intentions and non-social outcomes like purchase intentions complement each other well in the proposed model. Subsequently, the largely scarce concept in SMI research, consumer well-being, has also been incorporated to ensure followers' welfare. There are benefits for marketers in this proposed model as well. Influencer marketing is an emerging concept that is being embraced by brands everywhere. However, choosing the right influencer is challenging. Therefore, recognizing which types of influencers evoke consumer mimicry (and which don't) will ease the selection process. This will increase the efficiency of influencer marketing campaigns run by marketers and brands. That is not all; the aspect of consumer well-being will also make them rethink twice before collaborating with an SMI. Ensuring the welfare of consumers is a big responsibility for marketers and they must act accordingly. Influencers will also note consumer well-being and ensure that they do not evoke excessive materialistic desires among their followers.

**Funding:** This research received no external funding.

**Acknowledgments:** I acknowledge there was no external funding support

**Conflicts of Interest:** The author declares no conflict of interest.

## References

- Akhtar, O., & Wheeler, S. C. (2016). Belief in the immutability of attitudes both increases and decreases advocacy. *Journal of Personality and Social Psychology*, 111(4), 475.
- Appel, G., Grewal, L., Hadi, R., & Stephen, A. T. (2020). The future of social media in marketing. *Journal of the Academy of Marketing Science*, 48(1), 79–9.
- Arenas-Márquez, F. J., Martínez-Torres, M. R., & Toral, S. L. (2021). How can trustworthy influencers be identified in electronic word-of-mouth communities?. *Technological Forecasting and Social Change*, 166, 120596.
- Association of National Advertisers. (2018). Survey report: How ANA members are using influencer marketing. Available at <https://www.ana.net/getfile/26389>
- Au-Yong-Oliveira, M., Cardoso, A. S., Goncalves, M., Tavares, A., & Branco, F. (2019, June). Strain Effect-A Case Study About the Power of Nano-Influencers. In 2019 14th Iberian conference on information systems and technologies (CISTI) (pp. 1-5). IEEE.
- Bandura A. 1977. *Social Learning Theory*. Prentice-Hall: Englewood Cliffs, NJ.
- Bandura A. 1986. *Social Foundation of Thought and Action: A Social Cognitive Theory*. Prentice-Hall: Englewood Cliffs, NJ
- Berne-Manero, C., & Marzo-Navarro, M. (2020). Exploring how influencer and relationship marketing serve corporate sustainability. *Sustainability*, 12(11), 4392.
- Boerman, S. C. (2020). The effects of the standardized Instagram disclosure for micro-and meso-influencers. *Computers in Human Behavior*, 103, 199–207.
- Burnell, K., George, M. J., & Underwood, M. K. (2020). Browsing different Instagram profiles and associations with psychological well-being. *Frontiers in Human Dynamics*, 6.
- Campbell, C., & Farrell, J. R. (2020). More than meets the eye: The functional components underlying influencer marketing. *Business Horizons*, 63(4), 469-479.
- Casaló, L. V., Flavián, C., & Ibáñez-Sánchez, S. (2018). Influencers on Instagram: Antecedents and consequences of opinion leadership. *Journal of Business Research*, 117, 510–519.
- De Jans, S., Van de Sompel, D., De Veirman, M., & Hudders, L. (2020). # Sponsored! How the recognition of sponsoring on Instagram posts affects adolescents' brand evaluations through source evaluations. *Computers in Human Behavior*, 109, 106342.
- De Veirman, M., & Hudders, L. (2020). Disclosing sponsored Instagram posts: the role of material connection with the brand and message-sidedness when disclosing covert advertising. *International journal of advertising*, 39(1), 94-130.
- Djafarova, E., & Rushworth, C. (2017). Exploring the credibility of online celebrities' Instagram profiles in influencing the purchase decisions of young female users. *Computers in Human Behaviour*, 68, 1–7.
- Duffy, K. A., & Chartrand, T. L. (2015). Mimicry: causes and consequences. *Current Opinion in Behavioral Sciences*, 3, 112-116.
- Erz, A., Marder, B., & Osadchaya, E. (2018). Hashtags: Motivational drivers, their use, and differences between influencers and followers. *Computers in Human Behavior*, 89, 48–60.
- Fink, T. (2020). *Drivers of User Engagement in Influencer Branding*. Springer
- Ge, J., & Gretzel, U. (2018). Emoji rhetoric: A social media influencer perspective. *Journal of Marketing Management*, 34, 1272–1295.
- Hudders, L., De Jans, S., & De Veirman, M. (2021). The commercialization of social media stars: a literature review and conceptual framework on the strategic use of social media influencers. *International Journal of Advertising*, 40(3), 327-375.
- Hwang, Y., & Jeong, S. H. (2016). “This is a sponsored blog post, but all opinions are my own”: The effects of sponsorship disclosure on responses to sponsored blog posts. *Computers in Human Behaviour*, 62, 528–535.

- Jacob, C., Guéguen, N., Martin, A., & Boulbry, G. (2011). Retail salespeople's mimicry of customers: Effects on consumer behavior. *Journal of Retailing and Consumer Services*, 18(5), 381-388.
- Jang, K., Park, N., & Song, H. (2016). Social comparison on Facebook: Its antecedents and psychological outcomes. *Computers in Human Behaviour*, 62, 147–154.
- Jiménez-Castillo, D., & Sánchez-Fernández, R. (2019). The role of digital influencers in brand recommendation: Examining their impact on engagement, expected value and purchase intention. *International Journal of Information Management*, 49, 366–376.
- Jin, S. V., & Ryu, E. (2020). “I'll buy what she's# wearing”: The roles of envy toward and parasocial interaction with influencers in Instagram celebrity-based brand endorsement and social commerce. *Journal of Retailing and Consumer Services*, 55, 102121.
- Kay, S., Mulcahy, R., & Parkinson, J. (2020). When less is more: the impact of macro and micro social media influencers' disclosure. *Journal of Marketing Management*, 36(3-4), 248-278.
- Ki, C. W. C., & Kim, Y. K. (2019). The mechanism by which social media influencers persuade consumers: The role of consumers' desire to mimic. *Psychology & Marketing*, 36(10), 905-922.
- Ki, C. W. C., Cuevas, L. M., Chong, S. M., & Lim, H. (2020). Influencer marketing: Social media influencers as human brands attaching to followers and yielding positive marketing results by fulfilling needs. *Journal of Retailing and Consumer Services*, 55, 102133.
- Ki, C. W., Cuevas, L. M., Chong, S. M., & Lim, H. (2020). Influencer marketing: Social media influencers as human brands attaching to followers and yielding positive marketing results by fulfilling needs. *Journal of Retailing and Consumer Services*, 55, 102133.
- Kim, M., & Kim, J. (2020). How does a celebrity make fans happy? Interaction between celebrities and fans in the social media context. *Computers in Human Behavior*, 111, 106419.
- Ladhari, R., Massa, E., & Skandrani, H. (2020). YouTube vloggers' popularity and influence: The roles of homophily, emotional attachment, and expertise. *Journal of Retailing and Consumer Services*, 54, 102027.
- Lee, M. T., & Theokary, C. (2021). The superstar social media influencer: Exploiting linguistic style and emotional contagion over content?. *Journal of Business Research*, 132, 860-871.
- Lin, H. C., Bruning, P. F., & Swarna, H. (2018). Using online opinion leaders to promote the hedonic and utilitarian value of products and services. *Business horizons*, 61(3), 431-442.
- Lowe-Calverley, E., & Grieve, R. (2021). Do the metrics matter? An experimental investigation of Instagram influencer effects on mood and body dissatisfaction. *Body Image*, 36, 1-4.
- Martínez-López, F. J., Anaya-Sánchez, R., Esteban-Millat, I., Torrez-Meruvia, H., D'Alessandro, S., & Miles, M. (2020). Influencer marketing: brand control, commercial orientation and post credibility. *Journal of Marketing Management*, 36(17-18), 1805-1831.
- Oggers, C. L., & Jensen, M. R. (2020). Annual Research Review: Adolescent mental health in the digital age: facts, fears, and future directions. *Journal of Child Psychology and Psychiatry*, 61(3), 336-348.
- Oraedu, C., Izogo, E. E., Nnabuko, J., & Ogba, I. E. (2020). Understanding electronic and face-to-face word-of-mouth influencers: an emerging market perspective. *Management Research Review*.
- Park, J., Lee, J. M., Xiong, V. Y., Septianto, F., & Seo, Y. (2021). David and Goliath: When and Why Micro-Influencers Are More Persuasive Than Mega-Influencers. *Journal of Advertising*, 1-19.
- Rahman, K. T. (2021a). Driving Engagement on Instagram: A Comparative Analysis of Amazon Prime and Disney+. *SEISENSE Business Review*, 1(3), 1-11.
- Rahman, K. T. (2021b). Smartphone usage for learning among postgraduate students. *TARAN-AWAN Journal of Educational Research and Technology Management*, 2(1), 1-11.
- Rahman, K.T. (2021c) ‘Applications of Blockchain Technology for Digital Marketing: A Systematic Review’, in Bansal, R. (eds.) *Blockchain Technology and Applications for Digital Marketing*. IGI Global, pp. 16-31.

- Rahman, K. T. (2022). Influencer Marketing and Behavioral Outcomes: How Types of Influencers Affect Consumer Mimicry?. *SEISENSE Business Review*, 2(1), 56-68.
- Ruvio, A., Gavish, Y., & Shoham, A. (2013). Consumer's doppelganger: A role model perspective on intentional consumer mimicry. *Journal of Consumer Behaviour*, 12(1), 60-69.
- Schouten, A. P., Janssen, L., & Verspaget, M. (2020). Celebrity vs. Influencer endorsements in advertising: the role of identification, credibility, and Product-Endorser fit. *International journal of advertising*, 39(2), 258-281.
- Schwarz, R. (2021) Why and How Influencers Are Launching Their Own Brands. Available at: <https://www.forbes.com/sites/forbescommunicationscouncil/2021/11/02/why-and-how-influencers-are-launching-their-own-brands/?sh=1395cca62a40>
- Singh, J., Crisafulli, B., Quamina, L. T., & Xue, M. T. (2020). “To trust or not to trust”: The impact of social media influencers on the reputation of corporate brands in crisis. *Journal of Business Research*, 119, 464–480.
- Su, Y., Kunkel, T., & Ye, N. (2020). When abs do not sell: The impact of male influencers conspicuously displaying a muscular body on female followers. *Psychology & Marketing*, 1–12.
- Sundermann, G., & Raabe, T. (2019). Strategic communication through social media influencers: Current state of research and desiderata. *International Journal of Strategic Communication*, 13(4), 278-300.
- Torres, P., Augusto, M., & Matos, M. (2019). Antecedents and outcomes of digital influencer endorsement: An exploratory study. *Psychology & Marketing*, 36(12), 1267-1276.
- Trivedi, J., & Sama, R. (2020). The effect of influencer marketing on consumers’ brand admiration and online purchase intentions: An emerging market perspective. *Journal of Internet Commerce*, 19(1), 103-124.
- Van Reijmersdal, E. A., Rozendaal, E., Hudders, L., Vanwesenbeeck, I., Cauberghe, V., & van Berlo, Z. M. (2020). Effects of disclosing influencer marketing in videos: An eye tracking study among children in early adolescence. *Journal of Interactive Marketing*, 49, 94-106.
- Vrontis, D., Makrides, A., Christofi, M., & Thrassou, A. (2021). Social media influencer marketing: a systematic review, integrative framework and future research agenda. *International Journal of Consumer Studies*, 45(4), 617-644.